

# 3299 Rack Mount

The 3299 is part of the BypassP<sup>2</sup> product line, providing 1Gb bypass and active tap versatility and multi-functionality.



Figure 1: Rackmount populated with two modules with dual fiber bypass segments and one module with dual copper bypass segments. The right hand module with dual fiber bypass segment is fixed

The 3299 rackmount supports up to 6 full bypass segments in three dual segment bypass modules. Customers can mix all copper or all fiber modules according to their networking needs.

Additionally, the 3299 includes four 10Gb aggregation ports that aggregate the traffic from the multiple 1Gb segments. With this, much fewer links are required towards an aggregator or network packet broker device, reducing points of failure and reducing total cost of deployment.

## Multifunctional BypassP<sup>2</sup> Segment

A full bypass segment comprises two network and two appliance ports. The network ports offer, depending on the module, direct 1000Base-T (RJ45), single mode (SM) or multimode (MM) connectivity. The appliance ports utilize customer pluggable transceivers, and support the flexibility to connect appliances (tools) using 1Gb, SM, MM or copper. The dual copper bypass segment module includes direct 1000Base-T (RJ45) on the appliance ports.

The network ports connect to the non-blocking switching fabric via integrated transceivers. Fabric Flow technology provides the ability to forward the traffic from one segment to any other segment.

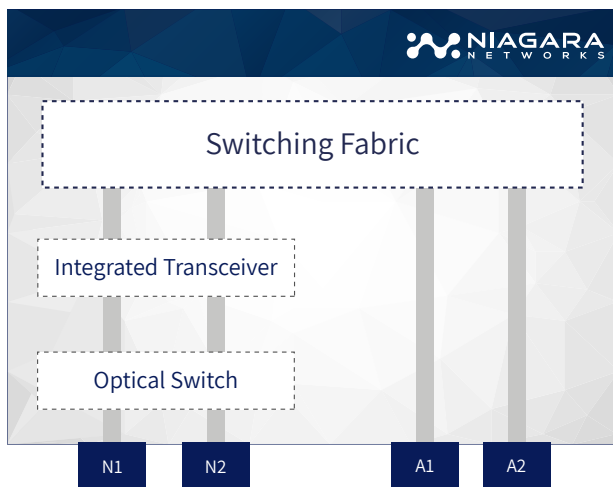

Figure 2: multi-purpose 4-port segment

## Product Highlights

### High Density:

- Up to 6 full 1Gb bypass segments
- 3 dual bypass modules

### Aggregation:

- 4 x 10Gb aggregation ports

### Multi-functional Segments

- Each segment comprises 2\*Network ports and 2\*Appliance ports
- Network ports support SX, LX and RJ45
- Bypass for inline deployments
- Active Tap split mode
- Active Tap aggregate mode

### Management:

- Robust command line interface (CLI)
- User-friendly, web-based user interface
- REST API for third-party integration and support
- Managed by Niagara Visibility Controller (NVC)
- Supports TACACS+, RADIUS, SNMP and NTP
- Centralized management

### Form Factor:

- 1U Rackmount
- Dual field-replaceable power supply



### Fabric Flow:

Mapping traffic flow relationships between source and destination ports

- Multi-functional bypass segment configuration
- High availability between primary and secondary bypass segments
- User-configurable packet heartbeat (ms resolution)

# Network Bypass Technology

Our signature BypassP<sup>2</sup> offers double-protection bypass technology. A failsafe optical relay on network ports, and a user-configurable heartbeat-generated packets on appliance ports.

In Bypass/Inline deployments, traffic from one side of the network is forwarded to the inline appliance, and through the inline appliance to the other side of the network. This is the common network deployment for inline security devices such as firewalls and intrusion detection systems.

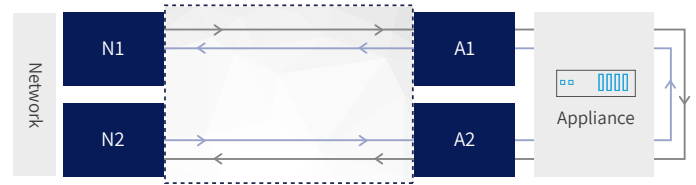

Figure 3: Inline deployment

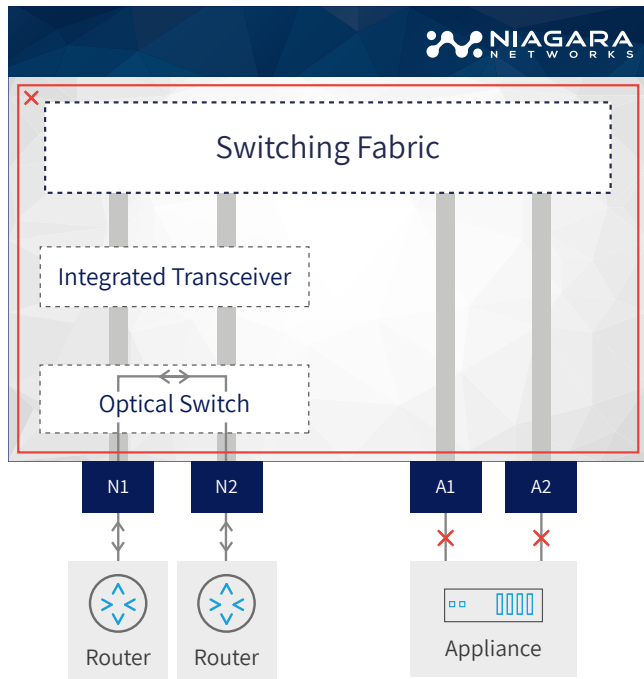

Figure 4: Power Failure Mode

**Failsafe protection** - protecting network traffic flow in the event of BypassP<sup>2</sup> failure. When power fails, as depicted in figure 4, the optical-relays ensure that the network flow continues uninterrupted. The optical relays can be configured fail open or fail close to meet specific deployment needs. An optical switch mechanism is the most reliable method for connecting inline devices to your network, while ensuring uninterrupted network services under all conditions.

**Heartbeat protection** - protecting network traffic flow in case of appliance failures. The BypassP<sup>2</sup> transmits a user-configurable heartbeat on the appliance ports as depicted in figure 5. In the event of an appliance malfunction (such as a software crash, system failure or loss of power depicted in figure 6), the failure is detected, and the BypassP<sup>2</sup> bypasses the traffic intended for the inline appliance to the network ports, allowing it to continue to flow through the network link. This feature also enables the network appliances to be removed and replaced without network downtime. Once the system is back up, or the power is restored to the appliance, it is detected by the BypassP<sup>2</sup> heartbeat mechanism, and network traffic is seamlessly diverted back to the inline device, allowing it to resume its critical functions.

Niagara's heartbeat mechanism is an integrated configurable sub-second-rate mechanism that is available independently for each segment. The number of missed heartbeat packets before entering bypass mode is configurable, so too is the number of received heartbeats to determine that the appliance is back on-line. BypassP2 heartbeat does not require additional drivers to be installed on connected appliances.

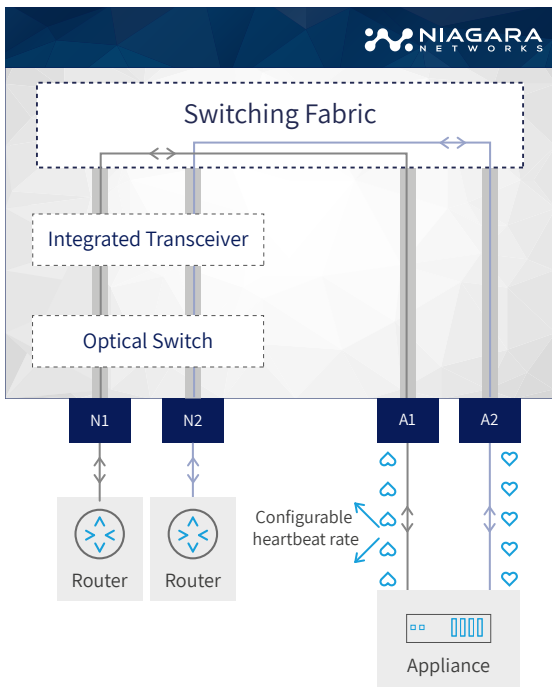

Figure 5: Normal inline Operation Mode

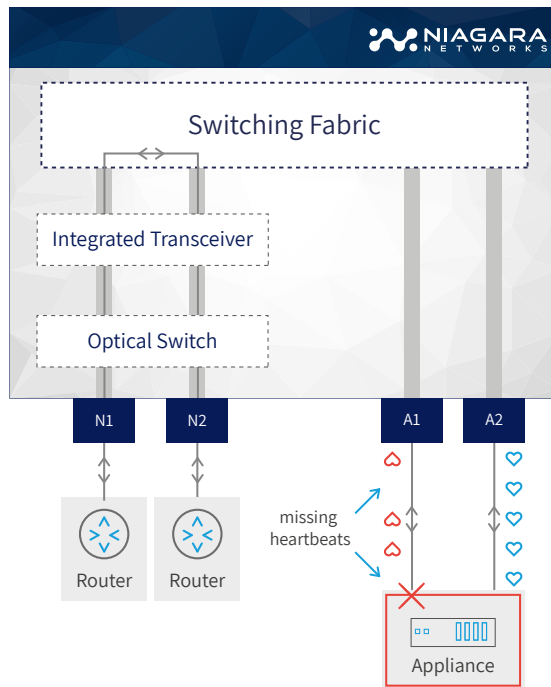

Figure 6: Appliance Failure Mode

## Active Tap (aggregation)

The bypass segment is configured as an active Tap, supporting one network link. Traffic on the network side is always maintained. Each appliance port receives a copy of the Rx from both sides of the network. This mode economizes on monitoring tool ports, in case the total traffic throughput from both network sides is below that of the single appliance port.

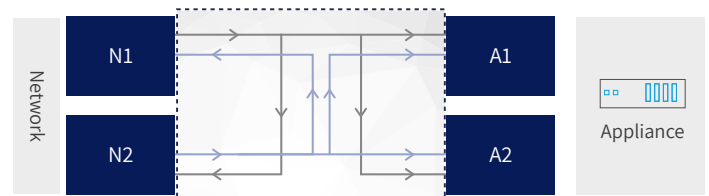

Figure 7: Active Tap (aggregation)

## Active Tap (split)

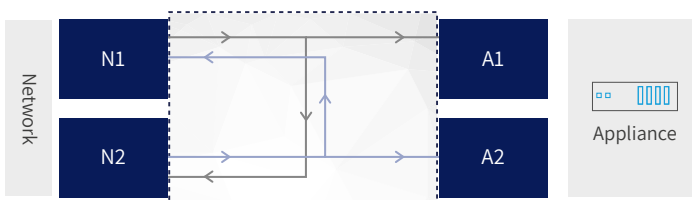

Figure 8: Active Tap (split)

The bypass segment is configured as an active Tap, supporting one network link. Traffic on the network side is always maintained. Each appliance port receives a copy of the Rx from one of the network ports.

## Manual Active Bypass

In this mode, the segment becomes transparent to the network traffic. Network traffic flows unimpeded between N1 and N2. This mode is useful for carrying out maintenance on the appliance ports without bringing the network side down.

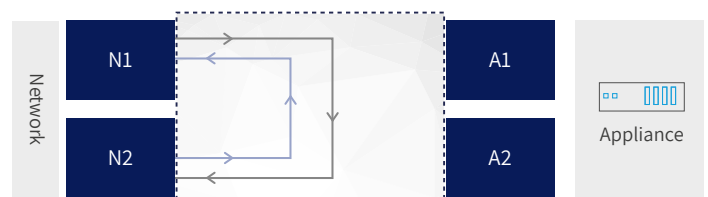

Figure 7: Manual Active Bypass Mode

# Common Use Cases

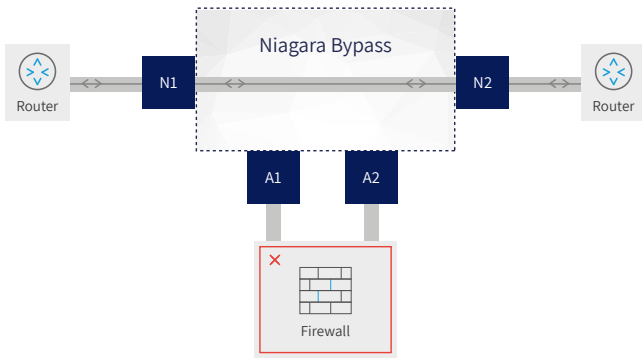

Figure 8: Protect network traffic in case of security appliance failure.

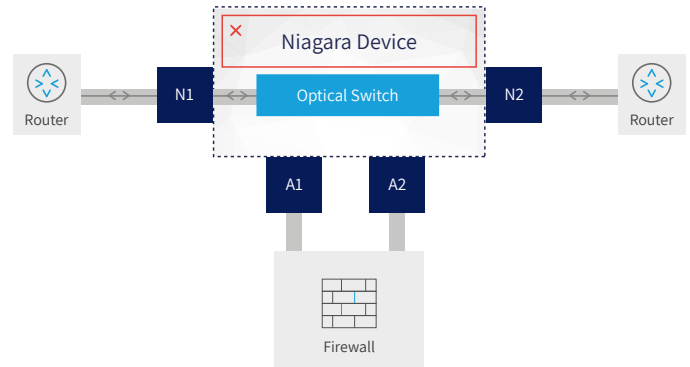

Figure 9: Hardware bypass in case of power or other major failure. Provides 100% network uptime.

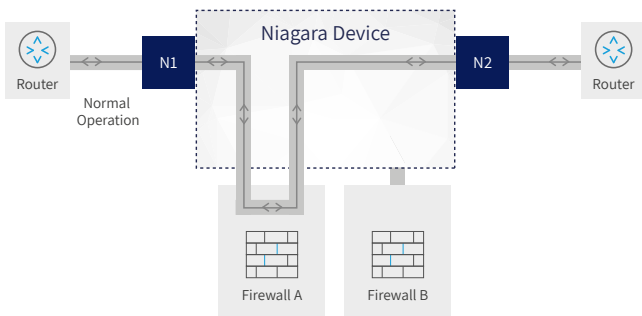

Figure 10: Supports high availability configuration. If Firewall A failed, Niagara device will switch traffic to Firewall B and protect network from security attack.

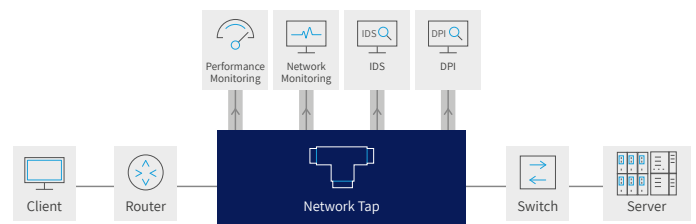

Figure 11: Send copy of network traffic to multiple tools.

Specifications			
Height	1.74in (44.2mm)	Operating Humidity	5%-95%
Length	24in (609.6.4mm)	Operating Temp	0° - 40 °C
Width	18.95in (481.33mm)	Max Power Consumption	25.41W
Max Raw Power	31.88W		

Emissions	Immunity
FCC Part 15B, ICES 003, EN55032	EN55024

Safety	Certifications
UL/CSA 60950-1, EN 60950-1, IEC 60950-1 CB Scheme with all country differences	North America (NRTL) European Union (EU) VCCI (Japan) 2014/35/EU Low Voltage Directive 2014/30/EU EMC Directive 2011/65/EU RoHS Directive 2012/19/EU WEEE Directive

Part Number	
3299-MN-AC	3299 main chassis AC, includes two internal power supply and four fan units
3299-MN-DC	3299 main chassis DC, includes two internal power supply and four fan units
3299-SG-1G-TXTX-2BPS	2 bypass segments of 1000Base-T. Each segment includes 2 network ports and 2 appliance ports
3299-SG-1G-SX-2BPS	2 bypass segments of 1GbE. Each segment includes 2 SX 50/125 network ports and 2 appliance ports. Appliance port transceivers ordered separately
3299-SG-1G-SX5-2BPS	2 bypass segments of 1GbE. Each segment includes 2 SX 62.5/125 network ports and 2 appliance ports. Appliance port transceivers ordered separately
3299-SG-1G-LX-2BPS	2 segments of 1GbE. Each segment includes 2 LX network ports and 2 appliance ports. Appliance port transceivers ordered separately

LICENSING	
	3299 license options
3299-LC-4P-10	License upgrade to enable 4x10GbE aggregation/uplink ports

## About Niagara Networks

Niagara Networks provides high performance network visibility solutions for seamless administration of security solutions, performance management and network monitoring. Niagara Networks products provide advantages in terms of network operation expenses, downtime, and total cost of ownership.

A former division of Interface Masters, Niagara Networks provides all the building blocks for an advanced Visibility Adaptation Layer at all data rates up to 100Gb, including Taps, bypass elements, packet brokers and a unified management layer. Thanks to its integrated in-house capabilities and tailor-made development cycle, Niagara Networks are agile in responding to market trends and in meeting the customized needs of service providers, enterprise, data centers, and government agencies.